

PROPRIETARY NOTICE: THIS DRAWING AND ALL INFORMATION THEREON IS THE PROPERTY OF COTTA TRANSMISSION COMPANY. THIS DRAWING IS NOT TO BE COPIED OR USED FOR THE PURPOSE OF MANUFACTURING EXCEPT BY WRITTEN CONSENT OF COTTA TRANSMISSION COMPANY.

ENGINEERING CHANGE NOTICES				
LTR	DESCRIPTION	ECN	DATE	BY
A	WAS ITEM 093	9378	03-May-01	SBL
B	B1 - DELETED ITEMS 3, 4, 61, 91, 108 B2 - ADDED NOTE B3 - ADDED VIEW	9387	10-May-01	SBL
C	ADDED ITEM 085	9608	19-Nov-01	SBL
D	SEE ECN	9668	09-Jan-02	RJL
E	WAS .003/.005 EP, DEL TEE + NIPPLE	10471	28-Oct-03	TAP
F	ADDED #X35 SPACER	10595	07-Jul-04	LJB

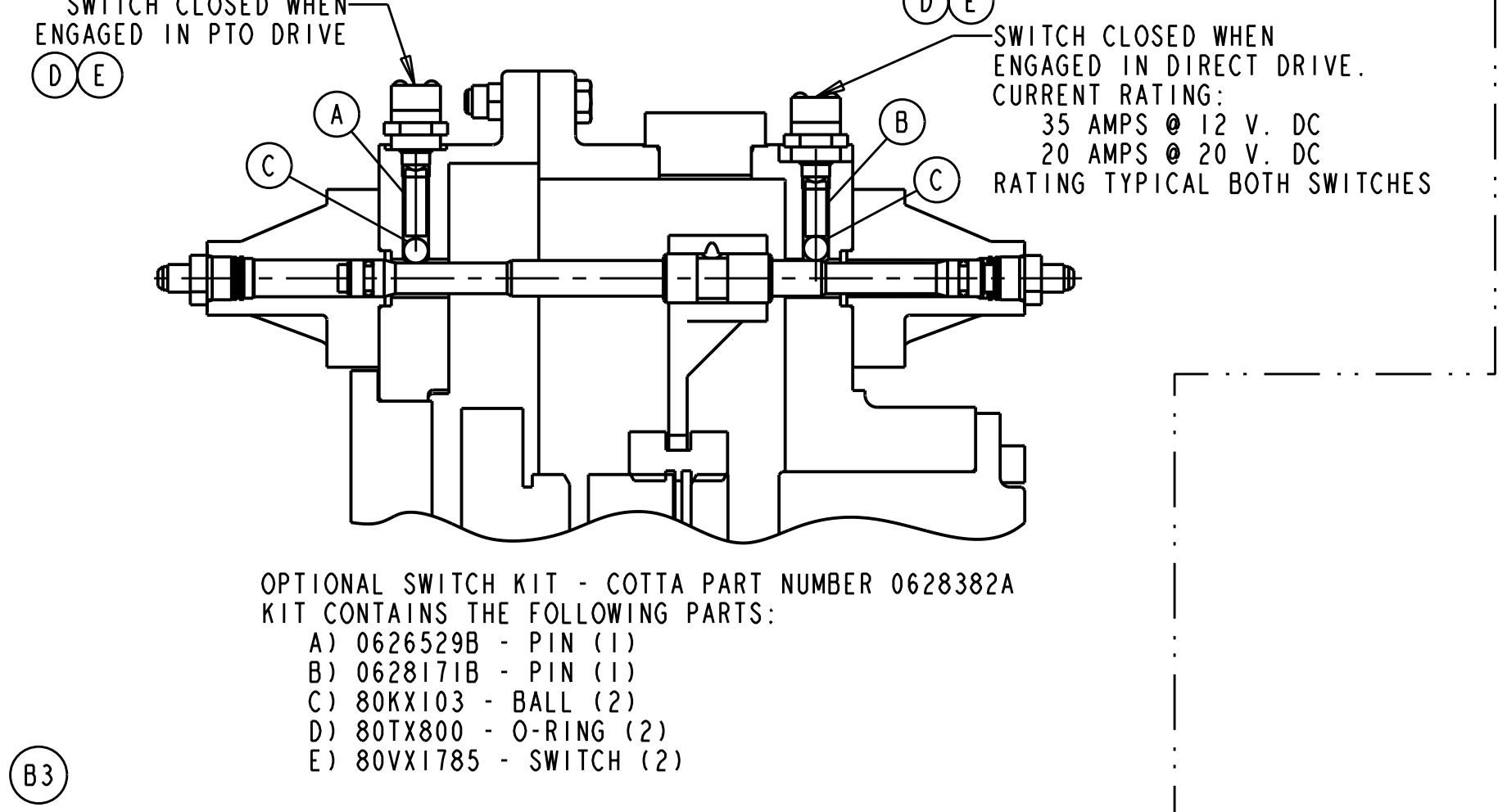
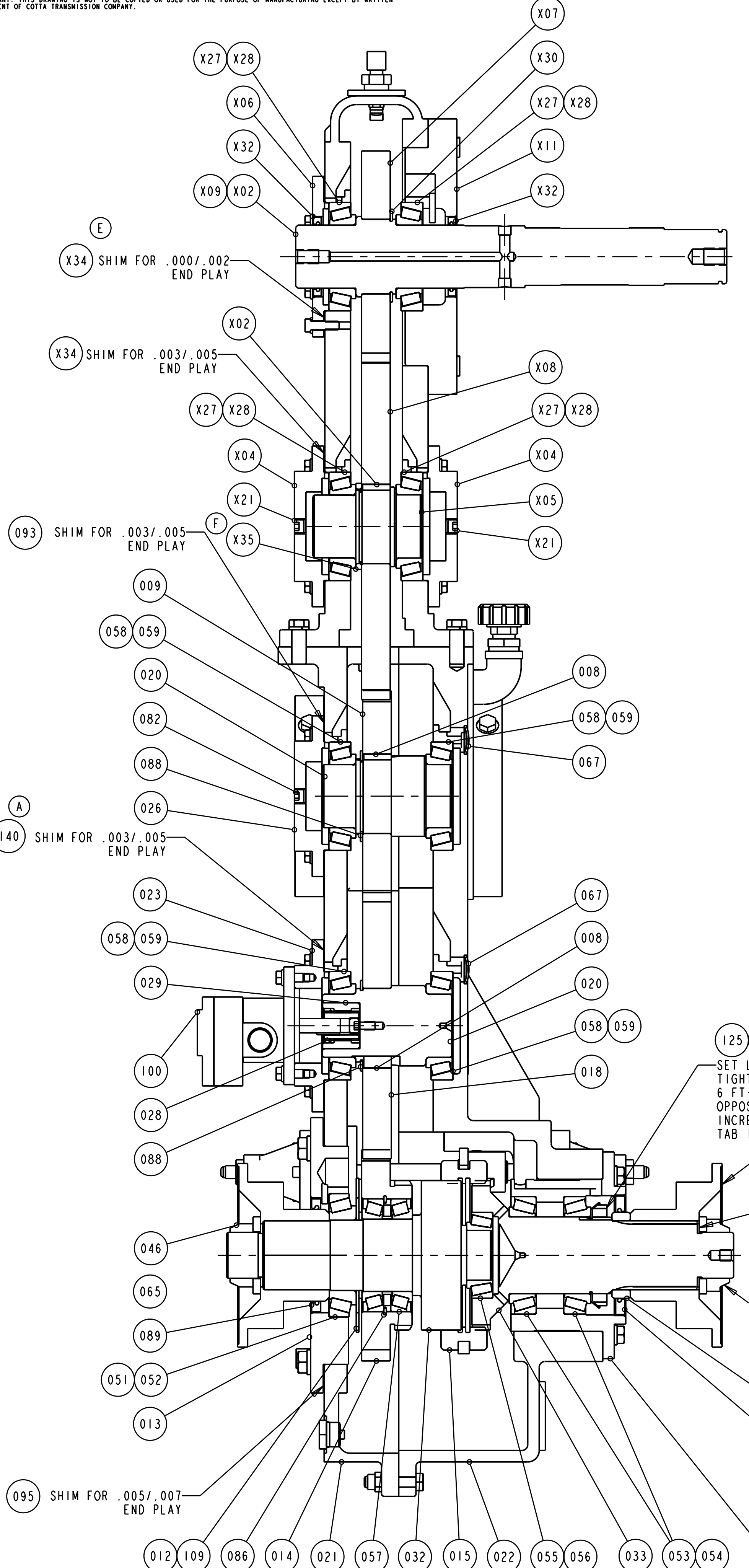

NOTE: USE SILICONE RUBBER SEALANT AT ALL SPLITLINES

NOTE: APPLY (1) DROP LOCTITE THREADLOCKER 242 OR EQUIVALENT TO ALL CAPSCREWS LOCATED IN THRU HOLES OF CASE & COVER

NOTE: STAMP SERIAL NUMBER ON PARTS 021, 022 & X10.

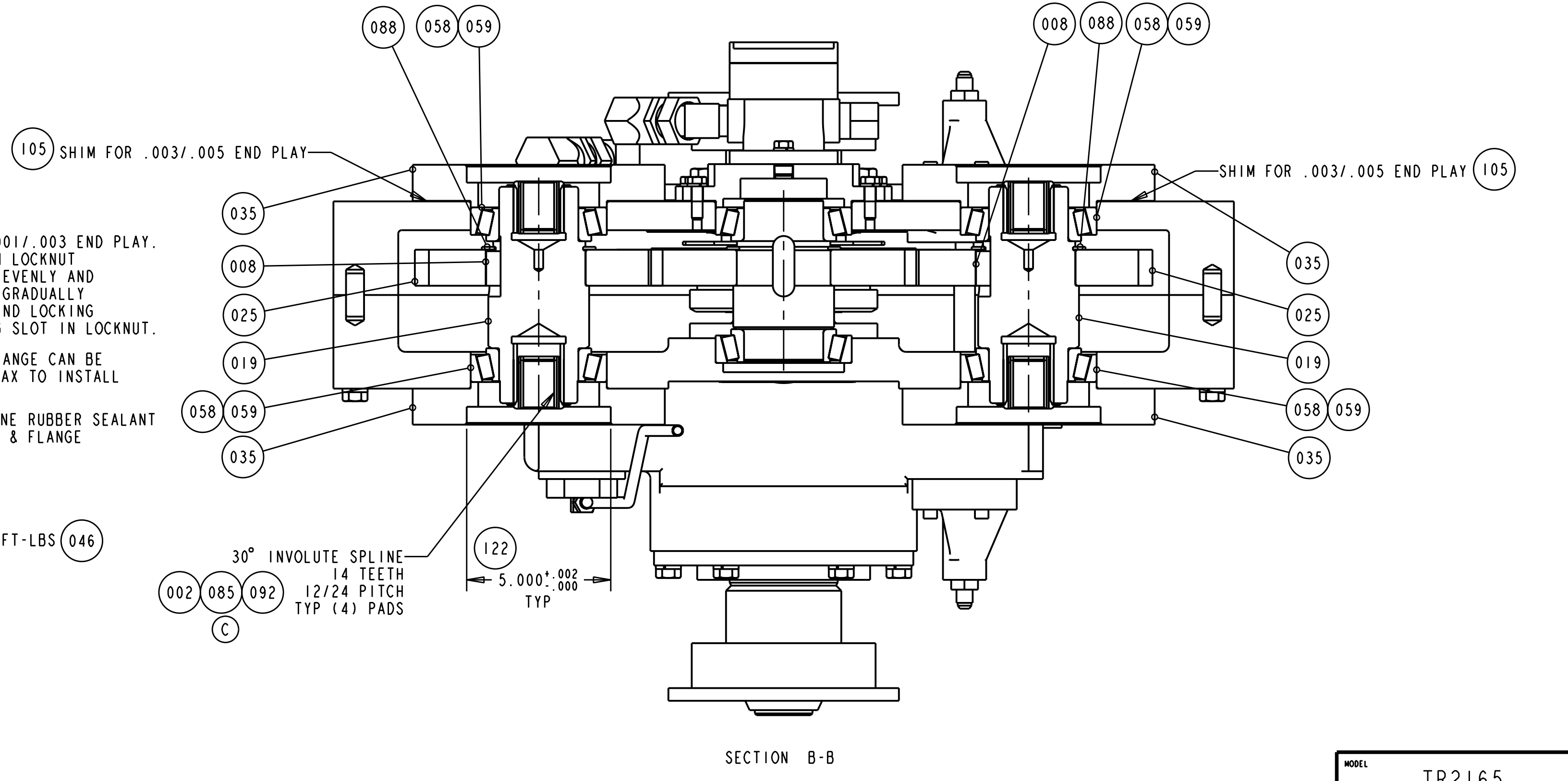
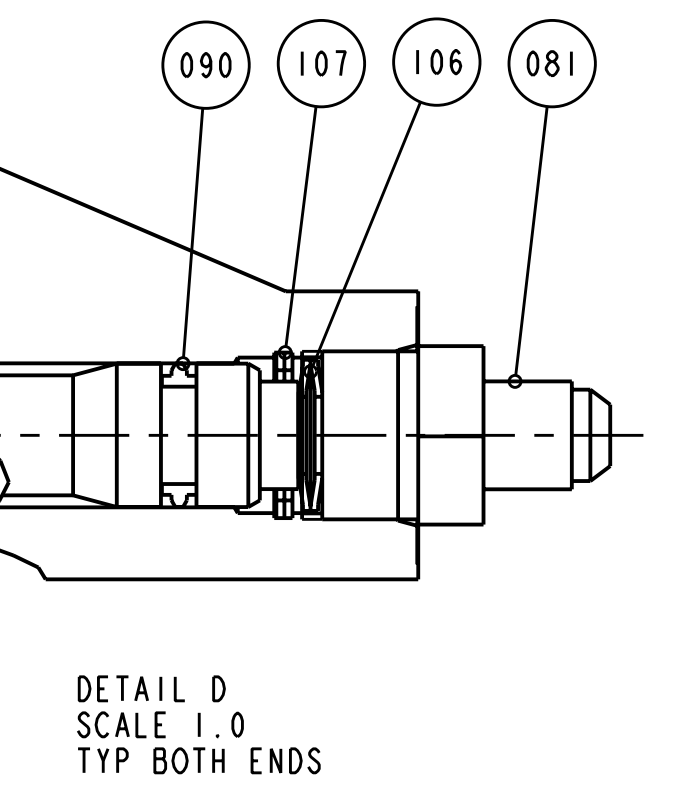
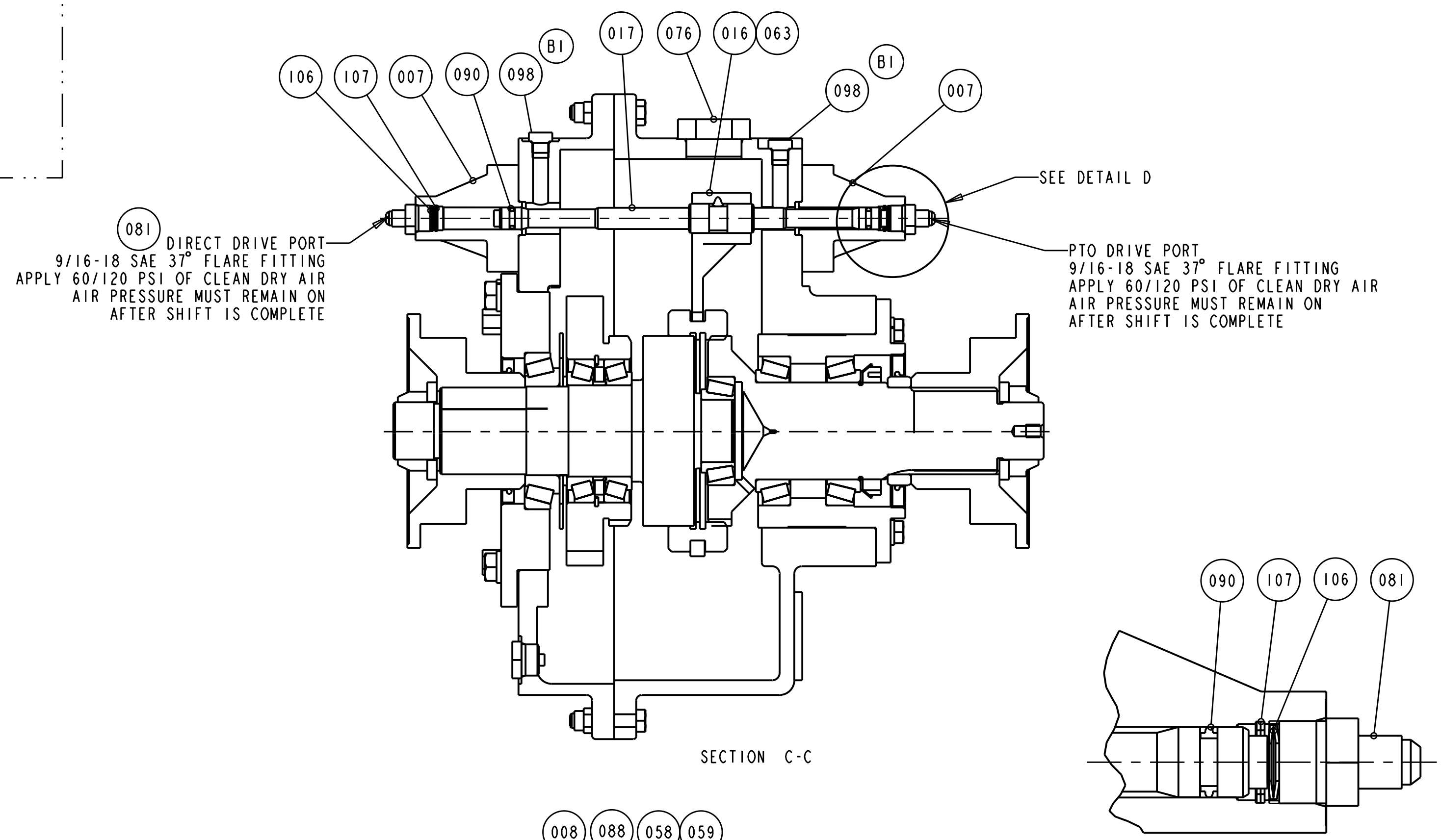

MODEL		REVISION DATE	
TR2165		07-Jul-04	
DRAWN RJL DATE 11-OCT-00		COTTA TRANSMISSION COMPANY, LLC 1301 PRINCE HALL DRIVE BELOIT, WI 53511	
CHECKED SBL DATE 11-OCT-00		PART NAME	
APPROVED TAP DATE 12-OCT-00		TRANSFER CASE	
SCALE 0.313 SHEET 2 OF 2		PART NUMBER	
DIMENSIONS ARE IN INCHES		TR2165-16	