

MODEL SI2E
SPEED INCREASER

Model SI2E is a heavy duty unit mounted speed increaser having engine rotation. It is available with a variety of input housings to fit the different engines. A wide range of ratios are offered.

The gears are helical, carburized and precision ground and are per AGMA specifications. The bearings are taper roller.

CAPACITY (nominal input torque):	1300 lb. ft.
MAXIMUM INPUT SPEED:	3000 RPM with SP214 & SP314 clutch 2000 RPM with SP218 clutch
MAXIMUM OUTPUT SPEED:	4500 RPM
RATIOS:	1.47, 1.66, 1.74, 1.97, 2.25, 2.46, 2.55, 3.0
BELL HOUSINGS:	SAE #0, #1, #2
CLUTCHES:	SP211, SP214, SP314, SP218
OUTPUT SHAFT:	2.500" diameter with 5/8 x 5/16 keyway
REAR SUPPORT:	4 holes 1/2-13 on rear cover for customers support plate
LUBRICATION:	ISO Viscosity Grade 68 Lube pump and filter furnished
COOLING:	Heat exchanger is furnished (loose)
WEIGHT:	800 lbs

Note: The output shaft can be located at 6 o'clock (below the input shaft) or at the 12 o'clock (above the input shaft) positions.

MODEL SIZE SPEED INCREASER

BELLHSG SAE #	DIM A
#2	16.62
#1	18.50
#1 (DEEP)	20.00
#0	23.50

OUTPUT CAN BE ORIENTED
AT 3, 6, 9, OR 12 O'CLOCK POSITION
CONTACT COTTA FOR MOUNTING HOLE LOCATION

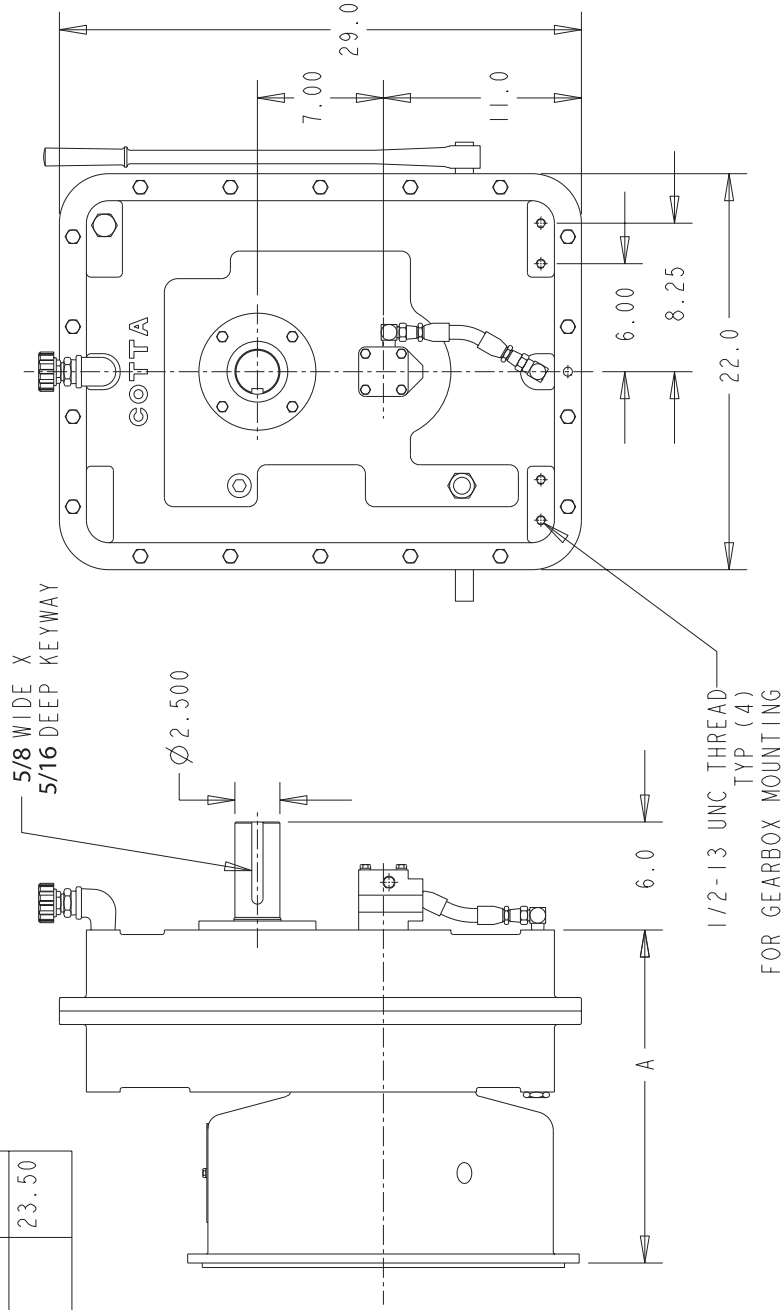

DO NOT USE DIMENSIONS ON THIS DRAWING FOR
INSTALLATIONS, USE CERTIFIED PRINT PROVIDED
WITH ORDERS.