

MODEL GO1945A
SPEED INCREASER

Model GO1945A is a heavy duty speed increaser having anti-engine rotation. The gears are helical, carburized to Rc 59-61 and are precision ground to AGMA class Q-12 for increased strength and quiet operation. The bearings are tapered roller. The case is stress relieved, fabricated steel.

This model is available with a SAE bell housing and clutch (or rubber block drive or coupling) for unit mounting to an engine. It can also be furnished with a stub input shaft for independent mounting.

CAPACITY:	7900 ft. lbs.
MAXIMUM INPUT SPEED:	2500 RPM
MAXIMUM OUTPUT SPEED:	4800 RPM
RATIOS:	3.52, 4.24, 5.0
INPUT HOUSINGS:	SAE #0, #00
INPUT CLUTCHES:	Overcenter type clutches, rubber block drives or couplings to fit various engine flywheels
OUTPUT SHAFT:	3.25" diameter x 6.0" long with .75 x .375 keyway
OUTPUT SHAFT LOCATION:	9 o'clock - output is to left of input when viewed from rear
LUBRICATION REQUIREMENT:	Lube pump is furnished for oil spray on bearings and gear. Sump is in case.
COOLING:	Heat exchanger furnished
ACCESSORIES FURNISHED:	Oil level sight gauge, filter, temperature/pressure switch, relief valve
OPTIONS:	Stub input shaft 4.500" diameter x 6" long with a 1" wide x 1/2" deep keyway when independently mounted
WEIGHT:	2450 lbs

07/31/03

MODEL G01945A SPEED INCREASER

INPUT HOUSING	A	B	CLUTCH SIZE
SAE #1	23.50	30.65	SP314, IBF214
SAE #0	24.75	31.90	SP218
SAE #0	27.00	34.15	SP318
SAE #00	29.00	36.15	SP 321
SAE #00	24.75	31.90	21" R.B.D.

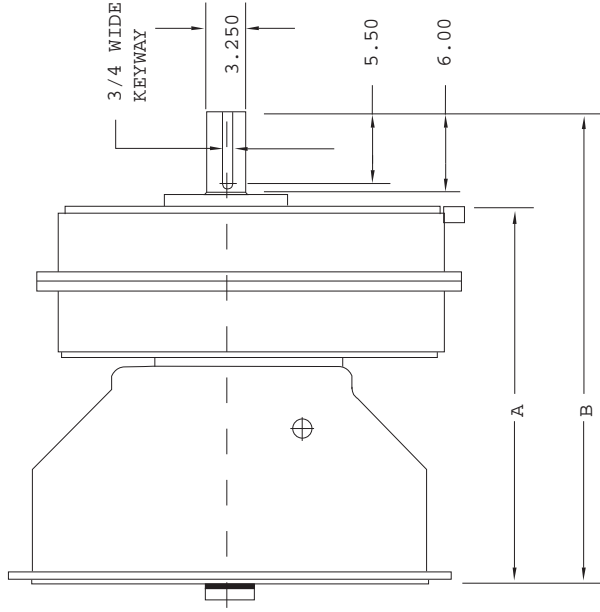

OUTPUT SHAFT SHOWN AT 9 O'CLOCK
(TO LEFT OF INPUT SHAFT)

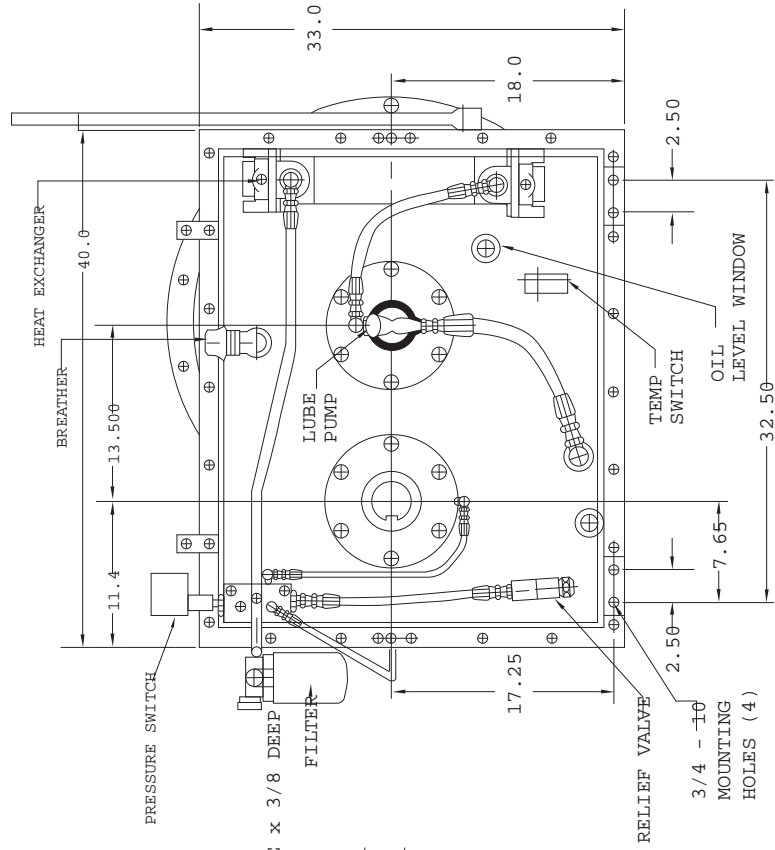

DO NOT USE DIMENSIONS ON THIS DRAWING FOR
INSTALLATIONS. USE CERTIFIED PRINT PROVIDED
WITH ORDER.

CUSTOMER TO FURNISH MOUNTING
BRACKETS TO SUIT.